

PROPER USE GUIDELINES

Cumulative Trauma Disorders can result from the prolonged use of manually powered hand tools. Hand tools are intended for occasional use and low volume applications. A wide selection of powered application equipment for extended-use, production operations is available.

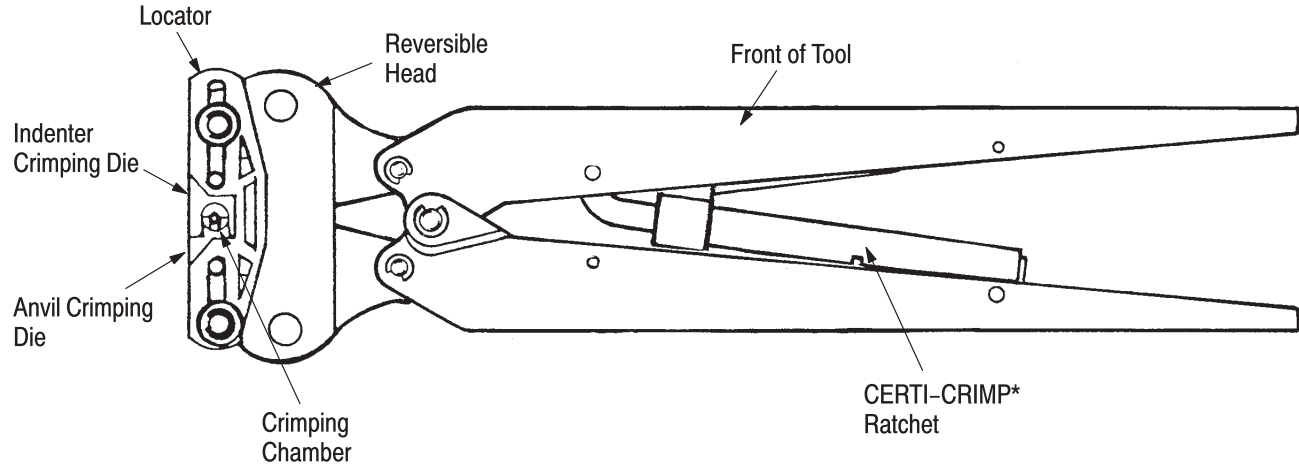

Figure 1

1. INTRODUCTION

Hand Crimping Tools 69376, 69376-1, 69376-2, and 69376-3 are designed to crimp TNC Series Single Crimp 50-Ohm connectors onto various size cables. Catalog 1307191 provides a guide for cable-to-connector selection.

Read these instructions thoroughly before using the hand tool.

NOTE

Dimensions in this instruction sheet are in millimeters [with inches in brackets]. Figures and illustrations are for identification only and are not drawn to scale.

Reasons for reissue of this instruction sheet are provided in Section 6, REVISION SUMMARY.

2. DESCRIPTION

Each hand tool features a reversible head which contains integral crimping dies: an indenter and an anvil. When closed, the dies form a crimping chamber with three sections: insulation, braid, and center contact. The sections simultaneously crimp the connector center contact, and the insulation and braid sections of the ferrule.

The locator provides proper positioning of the connector for crimping. The CERTI-CRIMP ratchet, which contains a short handle, ensures full crimping. Once engaged, the ratchet will not release until the

handles have been FULLY closed. The short handle is a "quick take-up" device to aid in closing the handles to complete the crimp. See Figure 1.

CAUTION

The crimping dies close before the ratchet releases. This design feature ensures full tensile strength of the crimp. Do not re-adjust the ratchet.

3. CRIMPING PROCEDURE

Strip the cable, and assemble the connector crimp end according to instruction sheet 408-9566. Then proceed as follows:

NOTE

To reverse the tool head for individual preference of using the tool with either hand, first remove the retaining rings and pins from the ends of the handle. Turn the head 180° as shown in Figure 2; then re-assemble.

1. Open the dies by closing the tool handles until the ratchet releases.
2. Position the crimp end on the anvil crimping die with the cable extending from the FRONT side of the tool. Make sure the center contact and ferrule are resting firmly in the crimping chamber. Refer to Figure 3.

CAUTION

BE SURE that the center contact bottoms on the center contact crimping section, and the ferrule is bottomed against the insulation and braid crimping sections.

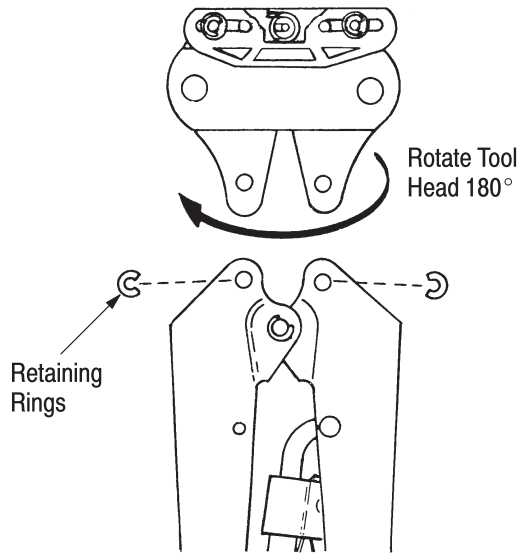

Figure 2

3. Close the handles part way by pulling the short handle, then grasp the tool handles and completely close the handles until the ratchet releases. See Figure 4.
4. Allow handles to open FULLY, then remove the crimp end. Inspect the crimp end to ensure a properly crimped assembly.

Crimping Connector

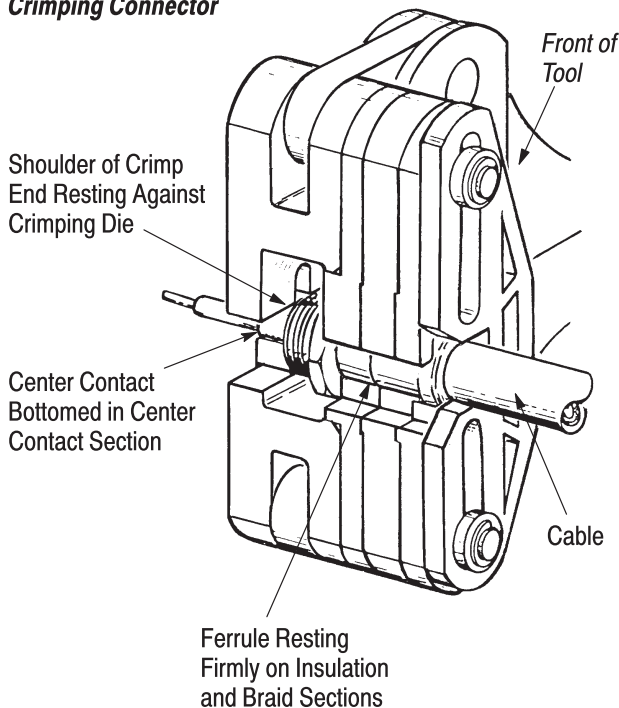

Figure 3

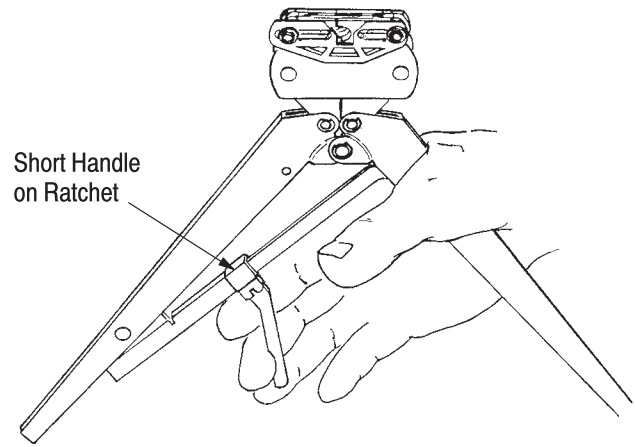

Figure 4

CAUTION Damaged product should not be used. If damaged product is evident, it should be replaced.

4. MAINTENANCE AND INSPECTION

It is recommended that a maintenance and inspection program be performed periodically to ensure dependable and uniform terminations. Though recommendations call for at least one inspection a month, frequency of inspection depends on:

1. The care, amount of use, and handling of the hand tool.
2. The presence of abnormal amounts of dust and dirt.
3. The degree of operator skill.
4. Your own established standards.

The hand tool is inspected before being shipped; however, it is recommended that the tool be inspected immediately upon arrival to ensure that the tool has not been damaged during shipment.

4.1. Daily Maintenance

1. Hand tool should be immersed (handles partially closed) in a reliable commercial degreasing compound to remove accumulated dirt, grease, and foreign matter. When degreasing compound is not available, tool may be wiped clean with a soft, lint-free cloth. Do NOT use hard or abrasive objects that could damage the tool.
2. Make certain that the retaining pins are in place and that they are secured with retaining rings.
3. All pins, pivot points, and bearing surfaces should be protected with a THIN coat of any good SAE 20 motor oil. Do NOT oil excessively.

4. When the tool is not in use, keep handles closed to prevent objects from becoming lodged in the crimping dies. Store the tool in a clean, dry area.

4.2. Lubrication

Lubricate all pins, pivot points, and bearing surfaces with SAE 20 motor oil as follows:

- Tools used in daily production—lubricate daily
- Tools used daily (occasional)—lubricate weekly
- Tools used weekly—lubricate monthly

Wipe excess oil from tool, particularly from crimping area. Oil transferred from the crimping area onto certain terminations may affect the electrical characteristics of an application.

4.3. Periodic Inspection

A. Visual Inspection

1. Close tool handles until ratchet releases and then allow them to open freely. If they do not open quickly and fully, the spring is defective and must be replaced. See Section 5, REPLACEMENT AND REPAIR.
2. Inspect head assembly for worn, cracked, or broken dies. If damage is evident, return the tool for evaluation and repair. See Section 5, REPLACEMENT AND REPAIR.

B. CERTI-CRIMP Ratchet Inspection

The CERTI-CRIMP ratchet on these hand tools should be checked to ensure that the ratchet does not release prematurely, allowing the crimping dies to open before they have fully bottomed. Obtain a 0.025 [.001] shim that is suitable for checking the clearance between the bottoming surfaces of the dies. Then, proceed as follows:

1. Select the appropriate crimp end and *maximum* size cable for the tool.
2. Position the crimp end and cable between the crimping dies according to Section 3, CRIMPING PROCEDURE.
3. Holding crimp end and cable in place, squeeze the tool handles together until the ratchet releases. Hold the tool handles in this position, maintaining just enough pressure to keep the dies closed.
4. Check the clearance between the bottoming surfaces of the crimping dies. If the clearance is .025 [.001] or less, the ratchet is satisfactory. If the clearance exceeds 0.025 [.001], the ratchet is out of adjustment and must be repaired. See Section 5, REPLACEMENT AND REPAIR.

C. Gaging the Crimping Chamber (Center Contact Section) For Tools 69376 and 69376-1

This inspection requires the use of a plug gage conforming to the dimensions shown in Figure 5.

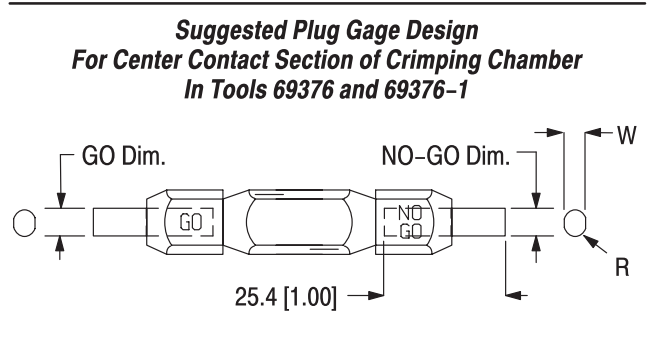

GAGE ELEMENT DIMENSIONS			
GO	NO-GO	“W” Width (Max)	“R” Radius (Max)
2.019-2.027 [.0795-.0798]	2.118-2.121 [.0834-.0835]	1.68 [.066]	0.838 [.033]

Figure 5

Tyco Electronics does not manufacture or market these gages. To gage the crimping chamber, proceed as follows:

1. Remove traces of oil or dirt from the crimping chamber and plug gage.
2. Close the tool handles until it is evident that the dies have bottomed; HOLD the tool in this position. Do NOT force the dies beyond initial contact.
3. Align the GO element with the crimping chamber. Push the element (without forcing it) straight into the chamber. The GO element must pass completely through the crimping chamber.
4. Align and try to insert the NO-GO element with the same crimping chamber. The NO-GO element may start entry but must not pass completely through the crimping chamber.

If the crimping chamber conforms to the gage inspection, it is considered dimensionally correct and should be lubricated with a THIN coat of any good grade SAE 20 motor oil. If not, the tool must be repaired before returning it to service. See Section 5, REPLACEMENT AND REPAIR.

D. Crimp Height Inspection

This inspection requires the use of a micrometer with a modified anvil, as shown in Figure 6. Crimp Height Comparator RS-1019-5LP is recommended and can be purchased from:

Shearer Industrial Supply Co. VALCO
(717) 767-7575 or (610) 691-3205

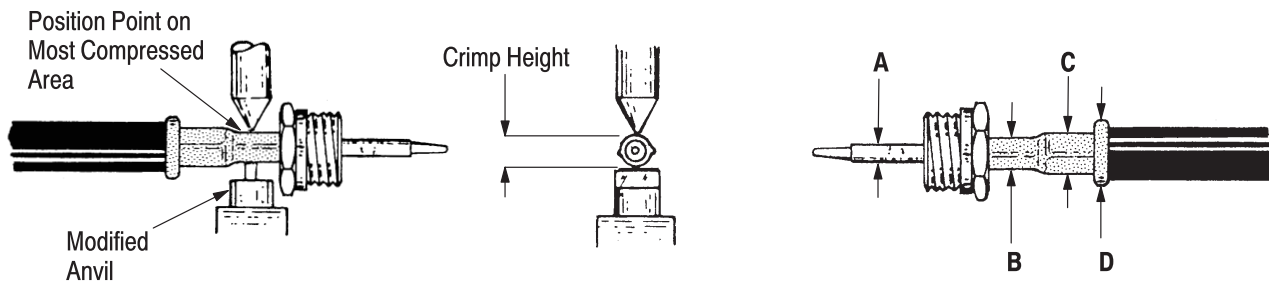

HAND TOOL	APPLIED PART NUMBER	CABLE TYPE	CRIMP HEIGHT DIMENSION			
			"A" Center Contact	"B" Braid	"C" Insulation	"D" Seal
69376	2-330953-2	RG-142A RG-142B	Use Plug Gage (Refer to Paragraph 4.3.C)	5.36-5.61 [.211-.221]	5.68-6.05 [.224-.238]	7.87-8.46 [.310-.333]
69376-2	131223-2 131228-1	RG-400	1.91-2.01 [.075-.079]			
69376-1	330884 330953	RG-58A RG-58C	Use Plug Gage (Refer to Paragraph 4.3.C)	4.95-5.21 [.195-.205]	5.31-5.66 [.209-.223]	
69376-3	330953 330884	RG-58 RG-58B	1.91-2.01 [.075-.079]			

Figure 6

1. Select a crimp end and appropriate cable from Figure 6. The crimp end part number and cable listed should be used for this inspection since the dimensions listed apply only to those combinations.

2. Refer to Section 3, CRIMPING PROCEDURE, and crimp the crimp end onto the cable accordingly.

3. Using a crimp height comparator, measure the braid, insulation, and seal sections of the ferrule, and the center contact crimp. Avoid measuring over any ridges. If the crimp height conforms to that dimension, the tool is considered dimensionally correct. If not, refer to Section 5 for information on obtaining customer repair service.

For additional information concerning the use of a plug gage or crimp height comparator, refer to instruction sheet 408-7424.

5. REPLACEMENT AND REPAIR

Customer-replaceable parts are listed in Figure 7. A complete inventory should be stocked and

controlled to prevent lost time when replacement of parts is necessary. Parts other than those listed should be replaced to ensure quality and reliability. Order replacement parts through your representative, or call 1-800-526-5142, or send a facsimile of your purchase order to 717-986-7605, or write to:

CUSTOMER SERVICE (038-035)
TYCO ELECTRONICS CORPORATION
PO BOX 3608
HARRISBURG PA 17105-3608

For customer repair service, please contact a representative at 1-800-526-5136.

6. REVISION SUMMARY

Revisions to this instruction sheet per EC 0990-1504-04 include:

- Updated document to corporate requirements
- Changed catalog number in Section 1, INTRODUCTION
- Changed information in table in Figure 6

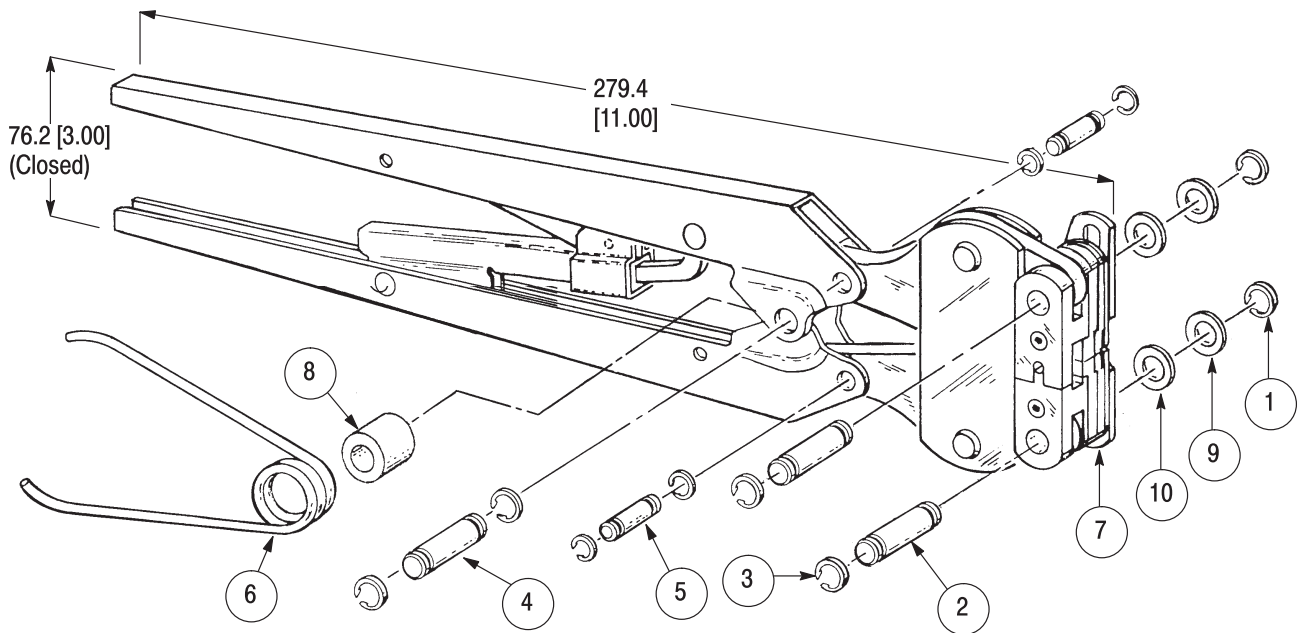

Weight: 680 g [1 lb, 8 oz]

REPLACEMENT PARTS

ITEM	PART NUMBER	DESCRIPTION	QTY PER TOOL
1	21045-3	RING, Retaining	1
2	1-306055-3	PIN, Retaining	1
3	21045-6	RING, Retaining	1
4	2-23620-9	PIN, Retaining	1
5	8-59558-2	PIN, Retaining	1
6	39364	SPRING	1
7	307089-2	LOCATOR	1
8	6-59591-7	COLLAR	1
9	24088-8	WASHER, Curved	1
10	125115-1	WASHER	1

Figure 7